



PDM32 - POWER DISTRIBUTION MODULE



MoTeC's 32 output Power Distribution Module is designed to provide electronically switched power to the various electrical systems in the vehicle such as motors, lights, solenoids, and electronic devices such as ECUs and data acquisition systems.

The module replaces conventional relays, fuses and circuit breakers to simplify wiring and switch requirements, while increasing reliability.

► FEATURES

- Each output is over-current, short circuit and thermal overload protected.
- Outputs programmable in 1 A steps and controllable via a combination of switch inputs, CAN messages and logic functions.
- Performs up to 200 logic operations and functions that can be used to selectively turn off systems.
- Provides full diagnostic information via CAN.

► SPECIFICATIONS

For full details, see user manual at www.motec.com/downloads.

Inputs

- 23 x switch inputs: range 0 to 51 V, resolution 0.2 V

Outputs

- 8 x 20 A outputs: 20 A continuous, 115 A transient (typical)
- 24 x 8 A outputs: 8 A continuous, 60 A transient (typical)

Communications

- 1 x CAN

Operating Voltage

- 30 V max

Environmental Protection

- Rubber seal on lid and connectors, conformal coating on PCB

Physical

- 1 x 37, 1 x 26, 1 x 8 and 1 x 1 pin Autosport connectors
- Case size 180 x 60 x 28 mm
- Weight 420 g

► COMPATIBILITY

MoTeC ECU Models

- M84, M400, M600, M800, M880, M1 Series (package dependant)

MoTeC Dash/Logger Models

- C125, C127, C185, C187, CDL3, SDL3, ADL3, ACL
- Discontinued: SDL, ADL2, ADL

► ACCESSORIES

MoTeC UTC #61059

⇒ UTC is required, not compatible with MoTeC CAN cable.

► SOFTWARE

Latest software can be found at www.motec.com/downloads.

PDM Manager software is used for:

- Configuring all inputs, outputs, CAN messages and conditions
- Monitoring all channel values
- Output testing
- Firmware updating.

► WIRING

➔ The PDM is wired onto the CAN bus. Please ensure wiring is according to CAN requirements and the CAN bus has at least one 100R terminating resistor. More information can be found in the user manual at www.motec.com/downloads.

To communicate to the PC, a CAN connector must be wired into the CAN bus. To connect the PDM directly to the CAN connector, wire according to the following table.

PDM Pin	PDM Name	CAN Connector Pin	CAN Connector Wire
A_10	CAN Lo	4	Green
A_11	CAN Hi	5	White
A_9	0 V	1	Black

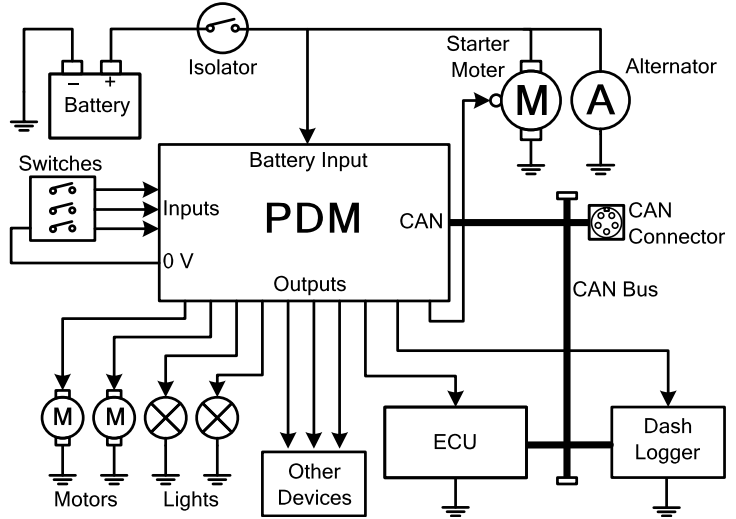

► DIMENSIONS AND MOUNTING

Measurements in mm.

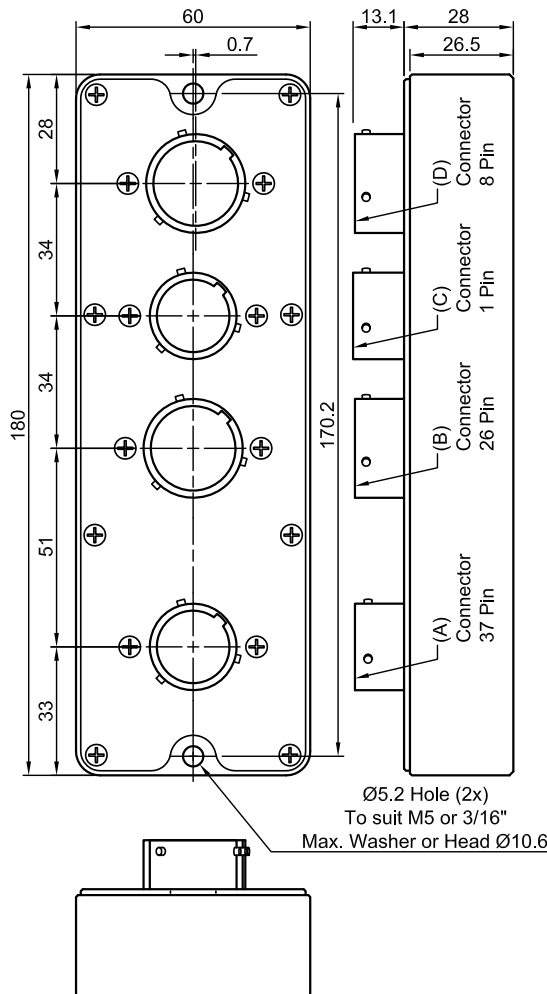

PINOUT

Connector A

37 pin autosport connector

Mating connector #68089

Pin	Function
A_1	Digital/Switch Input 1
A_2	Digital/Switch Input 2
A_3	Digital/Switch Input 3
A_4	Digital/Switch Input 4
A_5	Digital/Switch Input 5
A_6	0 V
A_7	0 V
A_8	0 V
A_9	0 V
A_10	CAN Low
A_11	CAN High
A_12	Digital/Switch Input 6
A_13	Digital/Switch Input 7
A_14	Digital/Switch Input 8
A_15	Digital/Switch Input 9
A_16	Digital/Switch Input 10
A_17	Digital/Switch Input 11
A_18	Digital/Switch Input 12
A_19	Digital/Switch Input 13
A_20	Digital/Switch Input 14
A_21	Digital/Switch Input 15
A_22	0 V
A_23	0 V
A_24	0 V
A_25	0 V
A_26	Digital/Switch Input 16
A_27	Digital/Switch Input 17
A_28	Digital/Switch Input 18
A_29	Digital/Switch Input 19
A_30	Digital/Switch Input 20
A_31	Digital/Switch Input 21
A_32	Digital/Switch Input 22

Pin	Function
A_33	Digital/Switch Input 23
A_34	Not Connected
A_35	Not Connected
A_36	Not Connected
A_37	Not Connected

Connector B

26 pin autosport connector

Mating connector #65040

Pin	Function
B_A	8 A Output 9
B_B	8 A Output 10
B_C	8 A Output 11
B_D	8 A Output 12
B_E	8 A Output 13
B_F	8 A Output 14
B_G	8 A Output 15
B_H	8 A Output 16
B_J	8 A Output 17
B_K	8 A Output 18
B_L	8 A Output 19
B_M	8 A Output 20
B_N	8 A Output 21
B_P	8 A Output 22
B_R	8 A Output 23
B_S	8 A Output 24
B_T	8 A Output 25
B_U	8 A Output 26
B_V	8 A Output 27
B_W	8 A Output 28
B_X	8 A Output 29
B_Y	8 A Output 30
B_Z	8 A Output 31
B_a	8 A Output 32
B_b	Batt –
B_c	Batt –

Connector C

1 pin waterproof connector

Mating connector:

#68093 (wire gauge #6 AWG)

#68094 (wire gauge #4 AWG)

Pin	Function
C_1	Batt +

Connector D

8 pin waterproof connector

Mating connector: #68092 (Deutsch AS616-08SN)

Pin	Function
D_A	20 A Output 1
D_B	20 A Output 2
D_C	20 A Output 3
D_D	20 A Output 4
D_E	20 A Output 5
D_F	20 A Output 6
D_G	20 A Output 7
D_H	20 A Output 8